

Experiment 2: The Speed of Light*

Modern Physics Laboratory
Department of Physics and Astronomy
Austin Peay State University

September 12, 2006

Abstract

In this experiment you will determine the value of the speed of light using Foucault's rotating mirror method.

1 Introduction

The velocity of light in free space is one of the most important and intriguing constants of nature. Whether the light comes from a laser on a desk top or from a star that is hurtling away at fantastic speeds, if you measure the velocity of the light, you measure the same constant value. In more precise terminology, the velocity of light is independent of the relative velocities of the light source and the observer.

Furthermore, as Einstein first presented in his Special Theory of Relativity, the speed of light is critically important in some surprising ways. In particular:

1. The velocity of light establishes an upper limit to the velocity that may be imparted to any object.
2. Objects moving near the velocity of light follow a set of physical laws drastically different, not only from Newton's Laws, but from the basic assumptions of human intuition.

With this in mind, it's not surprising that a great deal of time and effort has been invested in measuring the speed of light. Some of the most accurate measurements were made by Albert Michelson between 1926 and 1929. Michelson measured the velocity of light in air to be 2.99712×10^8 m/sec. From this result he deduced the velocity in free space to be 2.99796×10^8 m/sec.

2 A Qualitative Description

In this experiment, you will use a method for measuring the speed of light that is basically the same as that developed by Foucault in 1862 and used by Michelson in the 1920s. A diagram of the experimental setup is shown in Figure 1.

*Adapted from *Instruction Manual and Experiment Guide for PASCO Scientific Model OS-9261A, 62, and 63A Speed of Light Apparatus*.

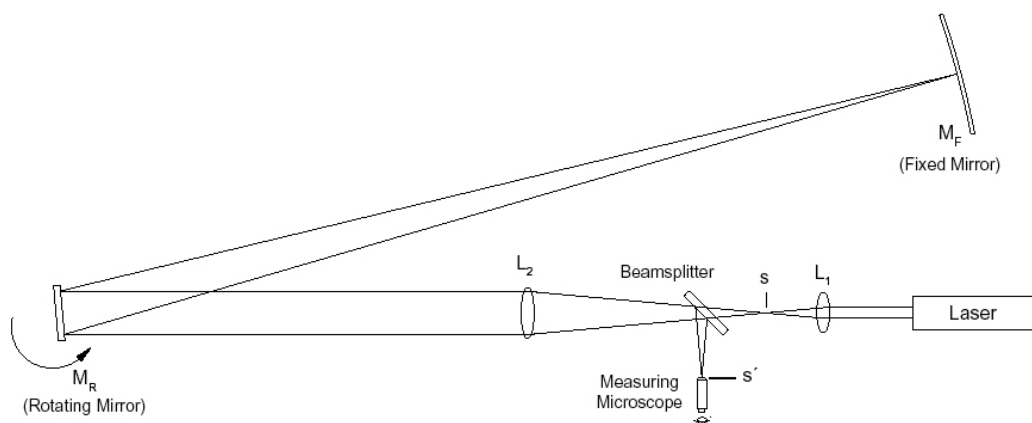

Figure 1: Focault's method

With all the equipment properly aligned and with the rotating mirror stationary, the optical path is as follows. The parallel beam of light from the laser is focused to a point image at point s by lens L_1 . Lens L_2 is positioned so that the image point at s is reflected from the rotating mirror M_R , and is focused onto the fixed, spherical mirror M_F . M_F reflects the light back along the same path to again focus the image at point s .

In order that the reflected point image can be viewed through the microscope, a beam splitter is placed in the optical path, so a reflected image of the returning light is also formed at point s' .

Now, suppose M_R is rotated slightly so that the reflected beam strikes M_F at a different point. Because of the spherical shape of M_F , the beam will still be reflected directly back toward M_R . The return image of the source point will still be formed at points s and s' . The only significant difference in rotating M_R by a slight amount is that the point of reflection on M_F changes.

Now imagine that M_R is rotating continuously at a very high speed. In this case, the return image of the source point will no longer be formed at points s and s' . This is because, with M_R rotating, a light pulse that travels from M_R to M_F and back finds M_R at a different angle when it returns than when it was first reflected. By measuring the displacement of the image point caused by the rotation of M_R , the velocity of light can be determined.

3 Equipment

OS-9261 Complete Speed of Light Apparatus:	SE-9367 0.5 mW He-Ne Laser
– OS-9263A High Speed Rotating Mirror Assembly	OS-9103 One-Meter Optics Bench
– Fixed Mirror	OS-9172 Laser Alignment Bench
– Measuring Microscope	OS-9142 Optics Bench Couplers
OS-9133 Lens (48 mm FL)	OS-9135 Lens (252 mm FL)
OS-9109 Calibrated Polarizers (2)	OS-9107 Component Holders (3)
OS-8514 Laser Adapter Kit	Alignment Jigs (2)

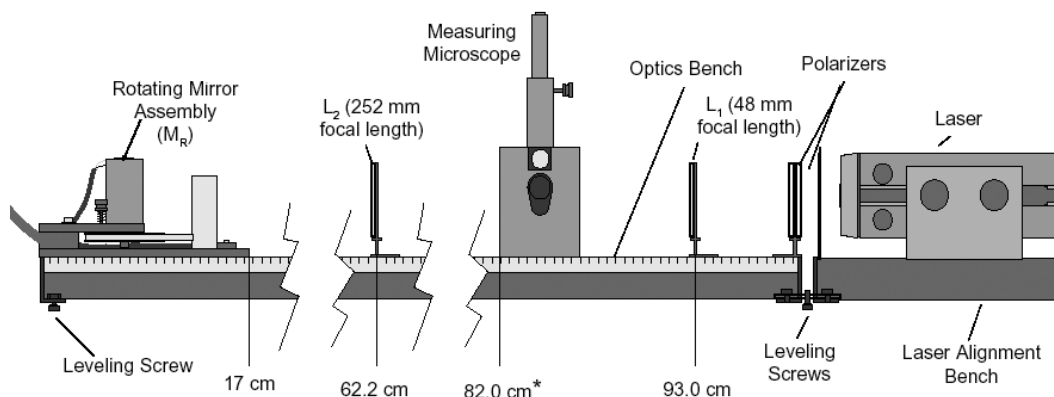

Figure 2: Equipment Alignment

4 Procedure

Thoroughly read and understand the provided equipment manual *Instruction Manual and Experiment Guide for PASCO Scientific Model OS-9261A, 62, and 63A Speed of Light Apparatus* (hereafter referred to as the *Manual*) before beginning this experiment. Pay particular attention to the “Equipment” section, as several pieces are delicate and easily damaged.

4.1 Setup and Alignment

IMPORTANT: Proper alignment is critical, not only for getting good results, but for getting any results at all. Please follow the detailed alignment procedure in the “Setup and Alignment” section of the *Manual* very carefully. Best results have been obtained by performing the experiment on the floor, and not using the laser alignment bench couplers (though you must be very careful not to bump the apparatus). *Allow yourself at least two hours to set up the experiment the first time.* Figure 2 shows the approximate positioning of the components with respect to the metric scale on the side of the Optics Bench. The exact placement of each component depends on the position of the Fixed Mirror and must be determined by following the steps of the alignment procedure. Below is a summary of the alignment procedure.

1. Align the laser so the laser beam strikes the center of M_R (use the alignment jigs).
2. Adjust the rotational axis of M_R so it is perpendicular to the beam (i.e. as M_R rotates, there must be a position at which it reflects the laser beam directly back into the laser aperture).
3. Insert L_1 to focus the laser beam to a point. Adjust L_1 so the beam is still centered on M_R .
4. Insert L_2 and adjust it so the beam is still centered on M_R .
5. Place the Measuring Microscope in position and, again, be sure that the beam is still centered on M_R .



Figure 3: Stray interference patterns in microscope view. Figure 4: Stretched spot in microscope view.

CAUTION: Do not look through the microscope until the polarizers have been placed between the laser and the beam splitter

6. Position M_F at the chosen distance from M_R (12–15 meters), so the reflected image from M_R strikes the center of M_F .
7. Adjust the position of L_2 to focus the beam to a point on M_F .
8. Adjust M_F so the beam is reflected directly back onto M_R .
9. Insert the polarizers between the laser and the beam splitter.
10. Focus the microscope on the image point.
11. Remove polarizers.

4.2 Alignment Hints

- Once you have the microscope focused, it may still be difficult to obtain a good spot. There may be several other lights visible in the microscope besides the spot reflected from the fixed mirror as in Figure 3.

The most common of these are stray interference patterns. These are caused by multiple reflections from the surfaces of the lenses, and may be ignored. If necessary, you may be able to eliminate them by angling the lenses $1\text{--}2^\circ$.

Stray Spots are most often caused by reflections off the window of the rotating mirror housing. To determine which spot is the one you must measure, block the beam path between the rotating mirror and the fixed mirror. The relevant spot will disappear.

If the spot you need to measure is significantly off-center, you can move it by adjusting the angle of the beamsplitter.

- Another common problem is a spot that is stretched with no easily discernible maxima (Figure 4). Check first to make sure that this is the spot you need by blocking the beam path between the moving and fixed mirrors. If it is, then twist L_2 slightly until the image coalesces into a single spot.

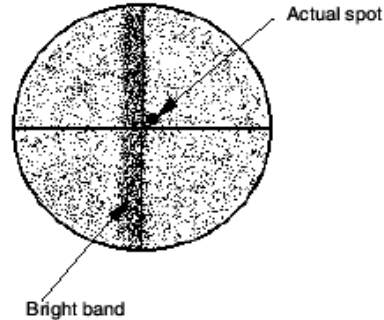

Figure 5: Microscope view with rotating mirror, M_R on.

- Once the mirror begins to rotate, it is safe to look into the microscope without the polarizers. You will notice that your carefully aligned pattern has changed: now the entire field is covered with a random interference pattern, and there is a bright band down the center of the field (Figure 5). Ignore the interference pattern; there's nothing you can do about it anyway. The band is the image of the laser when, once each rotation, the mirror reflects it into the microscope beamsplitter. This is also unavoidable.

Your actual spot will probably be just to one side of the bright band. You can check for it by blocking and unblocking the beam path between the rotating mirror and fixed mirror and watching to see what disappears.

If you aligned everything perfectly, the spot will be hidden by the bright band; in this case, make sure that you have a spot when the rotating mirror is fixed and is reflecting the laser to the fixed mirror. If you do have the correct spot under stationary conditions, then misalign the fixed mirror very slightly (0.004° or less) around the horizontal axis. This will bring the actual spot out from under the bright band.

4.3 Measurement

The speed of light measurement is made by rotating the mirror at high speeds and using the microscope and micrometer to measure the corresponding deflection of the image point. By rotating the mirror first in one direction, then in the opposite direction, the total beam deflection is doubled, thereby doubling the accuracy of the measurement.

1. With the apparatus aligned and the beam image in sharp focus (see the previous section), set the direction switch on the rotating mirror power supply to CW, and turn on the motor. If the image was not in sharp focus, adjust the microscope. You should also turn L_2 slightly askew (about $1-2^\circ$) to improve the image. To get the best image you may need to adjust the microscope and L_2 several times. Let the motor warm up at about 600 revolutions/sec for at least 3 minutes.
2. Slowly increase the speed of rotation. Notice how the beam deflection increases.

- Use the ADJUST knob to bring the rotational speed up to about 1,000 revolutions/sec. Then push the MAX REV/SEC button and hold it down. When the rotation speed stabilizes, rotate the micrometer knob on the microscope to align the center of the beam image with the cross hair in the microscope that is perpendicular to the direction of deflection. Record the speed at which the motor is rotating, turn off the motor, and record the micrometer reading.

NOTE: When reversing the direction of movement of the micrometer carriage, there will always be some movement of the micrometer knob before the carriage responds. Though this source of error is small, it must be eliminated. Just adjust the initial position of the micrometer stage so that you always turn the micrometer knob in the same direction as you adjust it.

- Reverse the direction of the mirror rotation by switching the direction switch on the power supply to CCW. Allow the mirror to come to a complete stop before reversing the direction. Then repeat your measurement as in step 3.

NOTES:

- When the mirror is rotated at 1,000 rev/sec or more, the image point will widen in the direction of displacement. Position the microscope cross-hair in the center of the resulting image.
 - The micrometer on the Measuring Microscope is graduated in increments of 0.01 mm for the beam deflections.
- The following equation is derived in the apparatus manual:

$$c = \frac{4AD^2\omega}{(D+B)\Delta s'} \quad (1)$$

where:

- c = the speed of light
- ω = the rotational velocity of the rotating mirror (M_R)
- A = the distance between lens L_2 and lens L_1 , minus the focal length of L_1
- B = the distance between lens L_2 and the rotating mirror (M_R)
- D = the distance between the rotating mirror (M_R) and the fixed mirror (M_F)
- $\Delta s'$ = the displacement of the image point, as viewed through the microscope. ($\Delta s' = s_1 - s$; where s is the position of the image point when the rotating mirror (M_R) is stationary, and s_1 is the position of the image point when the rotating mirror is rotating with angular velocity ω .)

When adjusted to fit the parameters just measured, it becomes:

$$c = \frac{8\pi AD^2(f_{cw} + f_{ccw})}{(D+B)(s'_{cw} - s'_{ccw})} \quad (2)$$

where f_{cw} and f_{ccw} are the CW and CCW mirror frequencies and s'_{cw} and s'_{ccw} are the CW and CCW micrometer readings, respectively.

Use equation 2 to calculate c . MAKE SURE TO DETERMINE ERRORS FOR A , B , D , and the CW and CCW micrometer readings. We will assume the motor frequencies are exact.

6. Repeat your measurement and calculation of c at least 5 times (you need not realign the apparatus between measurements).

5 Questions

You should ensure that your laboratory report addresses the following questions.

1. Did you encounter any alignment difficulties? Did you have to deviate from the procedure described here or in the *Manual* in any way? Did you have to employ any of the tips and hints outlined here or in the *Manual*?
2. Explain in your own words the derivation of equation 1. **Do not regurgitate the manual!**
3. Following the rules for error propagation given in the handout, calculate the error for each of the values of c you obtained.
4. What is your average value, with uncertainty, of c ?
5. Can the experimental error account for the differences between your value of c and the accepted value in air of 2.99702547×10^8 m/s? Discuss the accuracy of your measurement (see the “Notes on Accuracy” section of the *Manual*).